

GD830F-12 / GD830F - 24
Floor mount door retainer with override button

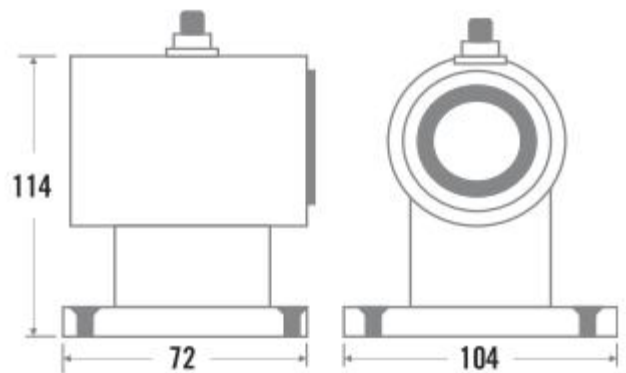

Features:

- Up to 70lb holding force
- **PLEASE NOTE: Holding force is dependent on door construction**
- Floor mount
- Includes armature plate
- Complete with override button
- GD830F-12 – 12vDC
- GD830F-24 – 24vDC

Specifications:

- 12vDC current consumption with 80amp current draw
- 24vDC current consumption with 40amp current draw