

ES-852T11/12/13H | W series

Starlight/WDR 2MP IR Eyeball Network Camera



- 1/2.8" 2MP Sony Starvis Sensor
- H.265+ Dual-stream Encoding
- IR Effective Range 10~20m
- High Quality Optical Lens 2.8mm/3.6mm/6mm optional
- IVA (Smart Function) Supported
- Multiple Web Browser Supported, IE/Safari/Chrome/Firefox
- P2P Cloud Function By Mobile App (AntarView Pro)
- Lightning Protection Up to 6KV
- IP67 Ingress Protection
- Built-in PoE



System Overview

W series 2MP IP cameras are project-oriented solution which is powered by starlight, true WDR, smart H.265+ and advanced cutting-edge Sony sensor for video monitoring.

It delivers crystal clear images and supports industry-leading IVA smart event alarm.

Cloud function is built-in for every device, which are more convenient and flexible for real-time and remote viewing.

Functions

H.265+

Delivering high quality video with up to 70% bandwidth saving. H.265+ is the evolutionary optimization of H.265 and traditional H.264. The Smart H.265+ includes a series of encoding strategies such as Dynamic ROI, smart 2D&3D noise reduction.

IVA (Intelligent Video Analysis)

It allows detection on multiple object behaviors, such as Tripwire, Intrusion, Objects Detection, Target Counting etc.

Protection

With precise mechanical and rugged casing design, it stands against water and dust with industrial IP67 rank.

Supports $\pm 30\%$ input voltage tolerance, it could work safely in extreme unstable power condition.

With working temperature range from -30°C to $+60^{\circ}\text{C}$, it works well in a variety of harsh outdoor environments.

Technical Parameters

Camera

Model	ES-852T11H	ES-852T12H	ES-852T13H	Flash/DDR	16MB/256MB
Image Sensor	1/2.8" 2MP Sony Starvis Sensor			S/N Ratio	More than 52dB
Min. Illumination	0.006Lux/F1.6 (color) 0 Lux with IR on			IR Distance	10~20m
Effective Pixels	1920(H)*1080(V)			IR LED No.	1

Lens

Focal Length	2.8mm	3.6mm	6mm	FOV	106°	96°	60°
Aperture	F1.6						

Video

Compression	H.265/H.264			WDR	120dB
Resolution	1080P(1920*1080)/1.3MP(1280*960)/720P(1280*720) D1(720*576)/Q720P(640*360)/CIF(352*288)			Day/Night	Auto(ICR)/Color/B/W
Bit Rate Control	CBR/VBR			White Balance	Supported
Bit Rate	16Kbps-32Mbps			Defog	Supported
Streaming	Dual stream			Noise Reduction	3D DNR
Frame Rate	Main stream: 1920*1080(1~25/30fps) Sub stream: 720*576(1~25/30fps)			Mirror	Supported
Digital Zoom	12x			Flip	Supported
Audio Compression	G.711u			BLC	Supported
				ROI	Support 4 fixed region for main stream and sub stream separately
				Anti-flicker	Supported
				Privacy Mask	4 Areas

Alarm & Audio

Video Detection	Motion Detection, Video Shelter	IVA	Tripwire/Intrusion/Object Left/Missing/Target Counting
Audio	N/A		

Network

Ethernet	1 RJ-45 port(10/100Mbps)	Web Browsers	IE/Firefox/Chrome/Safari
Protocols	TCP/IP, UDP, HTTP, IGMP, ICMP, DHCP, RTP/RTSP/DNS, DDNS, FTP, NTP, PPPoE, UPNP, SMTP, SNMP	VMS	AntarVis 2.0
Onvif	Onvif Profile S	Mobile App	AntarView Pro
Max. Online Users	2	Platform	Mac OS/ Windows/iOS/Android

General

Working Temperature	-30°C~+60°C	Ingress Protection	IP67
Working Humidity	10~90%	Dimensions	Φ102*93.2mm
Power Supply	PoE, IEEE802.3af	Net Weight	0.36KG
	DC12V±10%	Gross Weight	0.44KG
Power Consumption	< 3W		

Ordering Information

Type	Part Number	Description
2MP Camera	ES-852T11H	2MP Network Camera(2.8mm Lens)
	ES-852T12H	2MP Network Camera(3.6mm Lens)
	ES-852T13H	2MP Network Camera(6mm Lens)

Dimensions (mm)

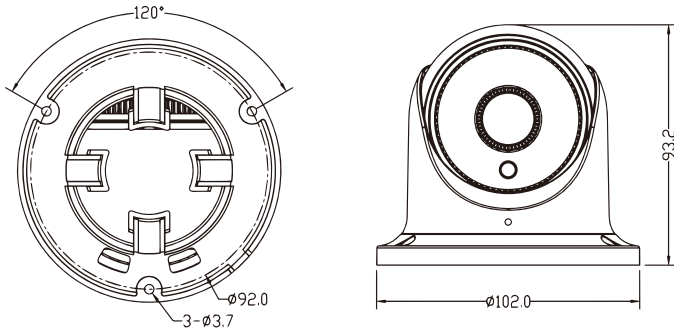

More details

ZKTECO CO.,LTD.
www.zkteco.com
E-mail: sales@zkteco.com

Copyright ©2018 ZKTECO CO., LTD. All rights reserved.

