



THANK YOU FOR VOTING TEXECOM

INSTALLATION MANUAL

Odyssey Series

Azura 360

Tempest

**External Sounder
& Strobe Unit**



Texecom
www.texe.com

Contents

Section	Page
1. Installation	3
1.1 Mounting the Unit	3
1.2 Patented Engineer Hold-Off Mode	3
1.3 Installing the Unit	3
1.3.1 Optional “Battery First” Connection Method	4
1.4 Installing Multiple Units	5
1.4.1 SCB Mode	5
1.5 Commissioning	6
2. Servicing	6
3. Safety	7
4. Technical Specification	8
5. Warranty	10
6. Registered Installer Application Form	11

1. Installation

1.1 Mounting the Unit

Select a suitable position to mount the unit, which satisfies the following criteria:

- Highly prominent for maximum deterrence
- Additional shelter (e.g. under the eaves) is an advantage
- High enough to be out of normal reach to deter tampering
- Safe ladder access
- Good cable access

In addition to the corner screw fixing points, the unit also has a central keyhole to simplify mounting and aid levelling.

Four screws and wall plugs are required for mounting the backplate to an even surface. An additional screw may be required to provide wall tamper by fitting through the screw hole next to the dual tamper microswitch. In doing so, care must be taken to leave the screw head slightly proud to ensure that the microswitch remains level and closes correctly when the outer cover is fitted.



NOTE

For safety reasons the unit must be mounted securely on a suitable wall.



NOTE

For maximum weatherproofing the unit should be flat to the wall.



NOTE

For brick walls, BS 4737 specifies a minimum of three No. 10 steel screws penetrating the brick (not the mortar or facing) by at least 40mm into suitable wall plugs.

1.2 Patented Engineer Hold-Off Mode

For safety reasons, each Texecom sounder and strobe unit incorporates a unique patented engineer Hold-Off mode. This mode prevents the unit from self-activating during installation and maintenance, thereby allowing only bona fide engineers access to the unit without any loss of tamper protection.

1.3 Installing the Unit

Connect the unit to the control panel as follows:

A (12V)	Permanent Positive Supply
B (BELL)	Negative Applied Output to Activate Siren
C (TAMP)	Negative Removed on Tamper Input
D (0V)	Permanent Negative Supply
S (STRB)	Negative Applied Output to Activate Strobe

Although the unit has been designed to be compatible with a wide range of control panels, for optimum performance, it is highly recommended that the unit should be used with Texecom's range of control panels.

The following table illustrates how to connect the unit to the Texecom range and other control panels:

	A	B	C	D	S
Texecom Control Panel	A	B	C	D	S
C&K Active 5, Securit	BELL +	S -	24 TAMPER	AUX -	ST -
Menvier TS510, 700, 800	BELL 12V	BELL TRIG	BELL TMP	0V	STB
Scantronic 9448 to 9800	+12V	BELL	TR	0V	STR

When connecting the unit to the control panel, it is recommended that wiring should be connected to the unit **first** and the control panel **second**. The unit should then be initially powered from the control panel. If the tamper circuit is open the siren will sound for 5 seconds after which it will automatically enter Hold-Off mode and disable Self-Activate (S/A) on tamper. This will prevent the unit from self-activating as long as the tamper circuit remains open. An open tamper circuit is indicated by only the left-hand side LED flashing. Connect the battery by moving the red battery wire from the "N/C" (No Connect) terminal to the "Battery +" terminal. Fit the outer cover and secure with the M6 screw(s) provided.

When the outer cover is replaced and the tamper circuit is closed, the LEDs will alternate rapidly, confirming that the tamper circuit is secure and signalling that S/A on tamper will be re-enabled within 2 minutes, after which the LEDs will alternate slowly to signal normal operation. If the tamper circuit is re-opened within the 2 minute period, then Hold-Off mode will be restored.



NOTE If the unit is powered up with the tamper circuit closed it will NOT sound for 5 seconds and will NOT enter Hold-Off mode. In order to disable the S/A function, before the cover is removed, Hold-Off mode should be invoked as for servicing (see Section 2).



NOTE For safety reasons the strobe is disabled during Hold-Off mode.



NOTE Hold-Off mode is immediately cancelled when the sounder is activated from the control panel.

1.3.1 Optional "Battery First" Connection Method

Hold-Off mode automatically cancels when both the tamper circuit is closed and power is supplied from the control panel. This allows installation engineers to power the unit from the internal battery and fit the outer cover, knowing that the unit cannot self-activate until after power has been supplied from the control panel.



NOTE If the tamper circuit is closed and the unit is powered by the battery only, the right LED will flash quickly to signal that the unit cannot self-activate until power has been supplied from the control panel.



Warning Prolonged "battery first" connection without power from the control panel may cause permanent damage to the internal battery. Texecom recommend that the unit is initially powered on battery only for no longer than 24 hours.

1.4 Installing Multiple Units

If more than one unit is connected to an installation, the current demand may exceed the rated current output of the control panel. This can be avoided by selecting the SCB mode on all but one of the connected units.

1.4.1 SCB Mode

In this mode the unit draws the majority of its sounding current from the built-in battery rather than from the control panel. Although volume is somewhat reduced, lowering the current demand on the control panel will enable the connection of additional sounder units. To select SCB Mode, the unit should first be powered from the built-in battery by connecting the red battery wire from the "N/C" (No Connect) terminal to the "Battery +" terminal. The unit will automatically enter Hold-Off mode to disable Self-Activate (S/A) on tamper, this will prevent the unit from self-activating until both the tamper circuit is closed and power is supplied from the control panel. Move the jumper JP1 to the SCB position before the unit is connected to the control panel.



NOTE

If the tamper circuit is closed and the unit is powered by the battery only, the right LED will flash quickly to signal that the unit cannot self-activate until power has been supplied from the control panel.

The following diagram illustrates how to wire multiple units together:

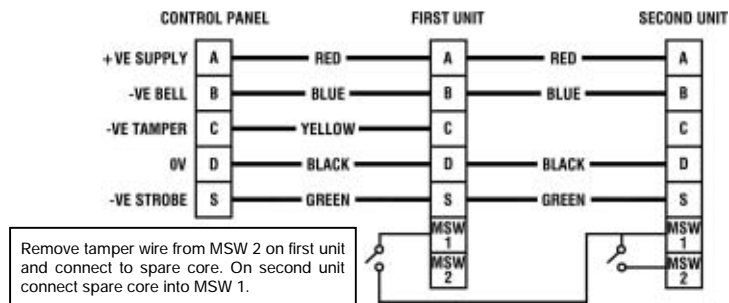

If the first unit is opened it will self-activate and a tamper will be signalled to the control panel. If the second unit is opened both units will self-activate and a tamper will be signalled to the control panel.



NOTE

When selecting SCB mode the battery must be connected before power is supplied from the control panel. If multiple units are connected to a single control panel without SCB mode selected, the sounding current may exceed the rated current of the control panel. If a unit is powered from a control panel with SCB mode selected but without the battery connected, the unit will not operate correctly due to the lack of power provided.



NOTE

The built-in battery will only be partially charged on delivery.

1.5 Commissioning

Most control panels have a method of testing the siren and strobe, which should be utilised for final testing. Failing this, simply arm the system and cause an alarm to confirm correct operation. Temporarily disconnect the positive supply to the unit at the control panel to confirm that the sounder self-activates.



NOTE The strobe does not self-activate.



NOTE Some control panels have an option to select the sounder cut-off time. The unit will sound for either 15 minutes or for the panel cut-off time, whichever is the shorter.

Please note, it cannot be guaranteed that the battery is fully charged on installation. When commissioning, the unit may require to be powered from the control panel for a period of time before the battery is sufficiently charged for self-activation.

2. Servicing

CAUTION: BEFORE OPENING THE COVER ALLOW AT LEAST 3 MINUTES AFTER THE LAST STROBE FLASH

Most control panels have a method of testing the siren and strobe, which should be utilised. Failing this, simply arm the system and cause an alarm to confirm correct operation. Temporarily disconnect the positive supply to the unit at the control panel to confirm that the sounder self-activates.



NOTE The strobe does not self-activate.



NOTE Some control panels have an option to select the sounder cut-off time. The unit will sound for either 15 minutes or for the panel cut-off time, whichever is the shorter.

For safety reasons if it is necessary to inspect the unit, the Self-Activate (S/A) on tamper function should be disabled before the cover is removed. This is achieved by using the unit's unique patented engineer Hold-Off mode. This is invoked by activating and de-activating the strobe three times within 30 seconds. Most control panels have a method of testing the strobe, which should be utilised. Failing this the strobe can be manually activated by connecting the S (STRB) wire to 0V at the control panel. Hold-Off mode is shown to be active with the tamper circuit secure by the right LED only flashing.

If the tamper circuit is not opened then Hold-Off mode will automatically start to cancel after 15 minutes, indicated by the LEDs alternating rapidly to signal that S/A on tamper will be re-enabled within a further 2 minutes.

Once the outer cover is removed the left LED only will flash to indicate that the tamper circuit is open.

When the outer cover is replaced, and the tamper circuit is closed, the LEDs will alternate rapidly, confirming that the tamper circuit is secure and signalling that S/A on tamper will be re-enabled within 2 minutes, after which the LEDs will alternate slowly to signal normal operation. If the tamper circuit is re-opened within the 2 minute period, then Hold-Off mode will be restored.

Summary of LED States	
Slow flashing LEDs	Normal operation
Left LED flashing only	Hold-Off active, tamper circuit open
Right LED flashing only	Hold-Off active, tamper circuit closed
Fast flashing LEDs	Hold-Off active but will cancel within 2 minutes



NOTE

If Hold-Off mode is invoked but the tamper circuit is not opened within 15 minutes then Hold-Off will automatically start to cancel, indicated by the LEDs alternating rapidly for a further 2 minutes.



NOTE

For safety reasons the strobe is disabled during Hold-Off mode.



NOTE

Hold-Off mode is immediately cancelled when the sounder is activated from the control panel.

3. Safety

INSTALLATION AND MAINTENANCE BY QUALIFIED SERVICE PERSONNEL ONLY

All strobes produce hazardous voltages. However, the unit includes dual circuit safety interlocks. When the strobe is de-activated it invokes a final flash to discharge the high voltage. Back-up circuitry guarantees discharge of the high voltage within 3 minutes.

For your own safety be sure to observe the following precautions when installing and servicing the unit:

- NEVER remove the cover when the strobe is flashing
- WAIT 3 minutes after the strobe stops flashing before removing the cover
- AVOID touching the part of the PCB labelled "Warning High Voltage"



The unit incorporates software which disables the strobe whilst the tamper switch remains open. This is a safety feature and cannot be disabled.



The piezo drive produces high voltages when the siren is sounding. While not directly hazardous, these voltages will cause discomfort and should be avoided, particularly when using tools or a ladder.



The piezo transformer TF1 will be hot during and after sounding. While not directly hazardous, touching it when hot will cause discomfort and should be avoided, particularly when using tools or a ladder.

Failure to observe the following precautions regarding the battery could lead to the danger of heating, ignition or explosion:

- Do not throw into a fire
- Do not heat
- Do not over-charge
- Do not reverse charge
- Do not short-circuit
- Do not disassemble
- Replace only with the same or equivalent type



NOTE Always observe local regulations when disposing of a battery.



Plastic bags can suffocate - always dispose of packaging carefully.

4. Technical Specification

Environmental	
Volume	
<i>Azura 360, Tempest:</i>	109dB Peak at 1m (A Weighting, 90°)
<i>Odyssey 1E, 2E, 3E & 4E:</i>	109dB Peak at 1m (A Weighting, 90°)
<i>Odyssey 1, 2, 3 & 4:</i>	115dB Peak at 1m (A Weighting, 90°)
Cut-Off Time:	≤15 minutes
Waterproof Coating:	Conformal
Operating Temperature:	-25°C (-13°F) to +55°C (+131°F)
Storage Temperature:	-25°C (-13°F) to +60°C (+140°F)
EMC Environment:	Residential / Commercial / Light Industrial / Industrial

Electrical	
Supply Voltage:	12V _{DC} (nominal)
Current Drain (typical at 12V_{DC})	
Quiescent:	15mA
Strobe:	110mA
Sounder	
<i>Azura 360, Tempest:</i>	300mA
<i>Odyssey 1E, 2E, 3E & 4E:</i>	300mA
<i>Odyssey 1, 2, 3 & 4:</i>	425mA
Standby Battery	
Type:	NiMh Stack
Voltage:	7.2V _{DC} (nominal)
Capacity:	320mAh
Flash Tube:	1Ws
Flash Rate:	1Hz (typical)*†
Discharge Time (≤60V_{DC}):	≤180 seconds
Comfort LEDs	
Brightness:	100mcd (typical)
Flash Rate (tamper secure):	1Hz alternating (typical)

* The flash rate will reduce to 0.125Hz after flashing for one hour (1 flash every 8 seconds). This is a software feature to reduce power consumption and cannot be disabled.

† The flash rate may reduce to 0.5Hz for supply voltages less than 12V_{DC}.

Physical	
Material	
<i>Azura 360, Tempest:</i>	3mm polycarbonate
<i>Odyssey 1E, 2E, 3E & 4E:</i>	3mm polycarbonate / 3mm ABS
<i>Odyssey 1, 2, 3 & 4:</i>	3mm polycarbonate
Orientation	
<i>Azura 360, Tempest:</i>	Vertical or horizontal
<i>Odyssey 1, 1E, 3 & 3E:</i>	Vertical
<i>Odyssey 2 & 2E:</i>	Horizontal
<i>Odyssey 4 & 4E:</i>	Vertical or horizontal
Mounting:	Corner mounting points plus central keyhole(s)
Tamper Detection	
<i>Azura 360, Tempest:</i>	Wall and lid
<i>Odyssey 1E & 2E:</i>	Wall and screw
<i>Odyssey 1, 2, 3 & 4:</i>	Wall, screw and lid
<i>Odyssey 3E & 4E:</i>	Wall and lid
Dimensions	
<i>Azura 360:</i>	319mm x 196mm x 77mm (12.56" x 7.80" x 3.64")
<i>Tempest:</i>	316mm x 205mm x 89mm (12.44" x 8.07" x 3.50")
<i>Odyssey 1 & 1E:</i>	318mm x 201mm x 66.5mm (12.52" x 7.91" x 2.62")
<i>Odyssey 2 & 2E:</i>	382mm x 242.2mm x 76mm (15.03" x 9.53" x 2.99")
<i>Odyssey 3 & 3E:</i>	315mm x 306mm x 78mm (12.40" x 12.04" x 3.07")
<i>Odyssey 4 & 4E:</i>	310mm x 196mm x 58.5mm (12.20" x 7.71" x 2.30")
Packed Weight	
<i>Azura 360, Tempest:</i>	1250g (44oz) approx.
<i>Odyssey 1, 1E, 3, 3E, 4 & 4E:</i>	1250g (44oz) approx.
<i>Odyssey 2 & 2E:</i>	1600g (56oz) approx.

Standards	
Safety:	Conforms to European Union (EU) Low Voltage Directive (LVD) 73/23/EEC (amended by 93/68/EEC).
EMC:	Conforms to European Union (EU) Electro-Magnetic Compatibility (EMC) Directive 89/336/EEC (amended by 92/31/EEC and 93/68/EEC).
Security Specific:	Conforms to EN50131-1/PD6662 Grade 3, Env Class IV Requirements



To comply with EU Directives the unit **MUST ONLY** be connected to a fused power source (≤5A) supplied from an isolating transformer.

The CE mark indicates that this product complies with the European requirements for safety, health, environmental and customer protection.

5. Warranty

All Texecom products are designed for reliable, trouble-free operation. Quality is carefully monitored by extensive computerised testing. As a result the *Azura 360*, *Tempest*, *Odyssey 1E*, *Odyssey 2E*, *Odyssey 3E* and *Odyssey 4E* are covered by a two year warranty against defects in material or workmanship (details on request).

The *Odyssey 1*, *Odyssey 2*, *Odyssey 3* and *Odyssey 4* are covered by a five year warranty.

Because the *Azura 360*, *Tempest* and *Odyssey Series* are not complete alarm systems but only a part thereof, Texecom cannot accept responsibility or liability for any damages whatsoever based on a claim that a unit failed to function correctly. Due to our policy of continuous improvement Texecom reserve the right to change specification without prior notice.

Azura 360, *Tempest* and *Odyssey* are trademarks of Texecom Ltd.

6. Registered Installer Application Form

Partially Completed Forms CANNOT be accepted.
Please use Black Ink and Block Capitals.

Name:	_____	Position:	_____
Company:	_____	Fax:	_____
Tel:	_____	E-Mail:	_____
Mobile:	_____	Website:	_____
Address:	_____ _____		
Country:	_____	Postcode:	_____

Which Distributors do you buy from?

(Indicate at least one).

1	_____
2	_____
3	_____

How many of the following products do you currently install each month?

Motion Detectors:

Control Panels (Domestic):

Perimeter Detectors:

Control Panels (Commercial):

Smoke Detectors:

External Sounders:

UK installers: Fax back to 01706 223450 or post to the address overleaf.
International installers: Fax back to 44 161 8815147.

Alternatively register online at www.texec.com



There's only ONE way to get

FREE

TECHNICAL SUPPORT...

REGISTER!

And receive the following exclusive benefits:

- **Access to the Secure Area of the Texecom Website**
 - **Freephone Technical Helpline***
 - **Free Product Voucher***
 - **Free Product Training***
 - **Latest Product Information**

Register online at www.texe.com or simply complete the form on the reverse of this page and return it to Texecom to become a Registered Texecom Installer.

***Available for UK registered Installers only.**

Texecom
www.texe.com

Texecom Limited. Bradwood Court, St. Crispin Way, Haslingden,
Lancashire BB4 4PW.

Website: www.texe.com

Technical Support (non-registered installers):

01706 234811

Calls charged at normal rate.